OWNER'S MANUAL

ELECTRIC CHAIN HOIST ED SERIES

125 through 525 Lb. Capacity

Code, Lot and Serial Number

⚠ WARNING

This equipment should not be installed, operated or maintained by any person who has not read and understood all the contents of this manual. Failure to read and comply with the contents of this manual can result in serious bodily injury or death, and/or property damage.

HARRINGTON
HOISTS AND CRANES

9.0 Parts List

When ordering Parts, please provide the Hoist code number, lot number and serial number located on the Hoist nameplate (see fig. below).

Reminder: Per sections 1.1 and 3.9.4 to aid in ordering Parts and Product Support, record the Hoist code number, lot number and serial number in the space provided on the cover of this manual.

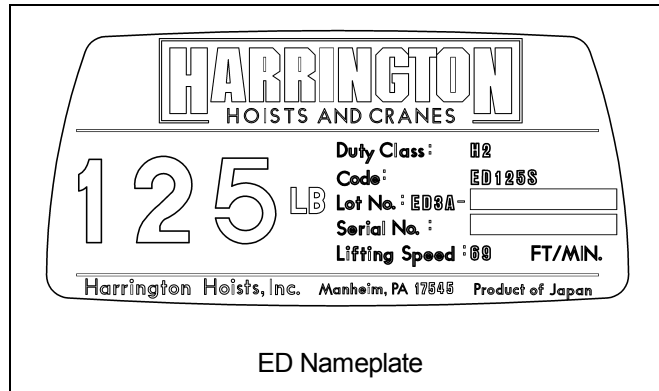

The parts list is arranged into the following sections:

Section	Page
9.1 Housing, Motor, and Gearing Parts.....	42
9.2 Power Supply and Pendant Parts	46
9.3 Electric Parts	50
9.4 Mini Trolley Parts.....	52

A designator is used to distinguish parts that apply only to a particular model or option. Refer to Section 2 for hoist model numbers and additional descriptions. The designators are:

S = Single Speed

DS = Dual Speed

DA= Dual Adjustable Speed

9.1 Housing, Motor, and Gear Parts

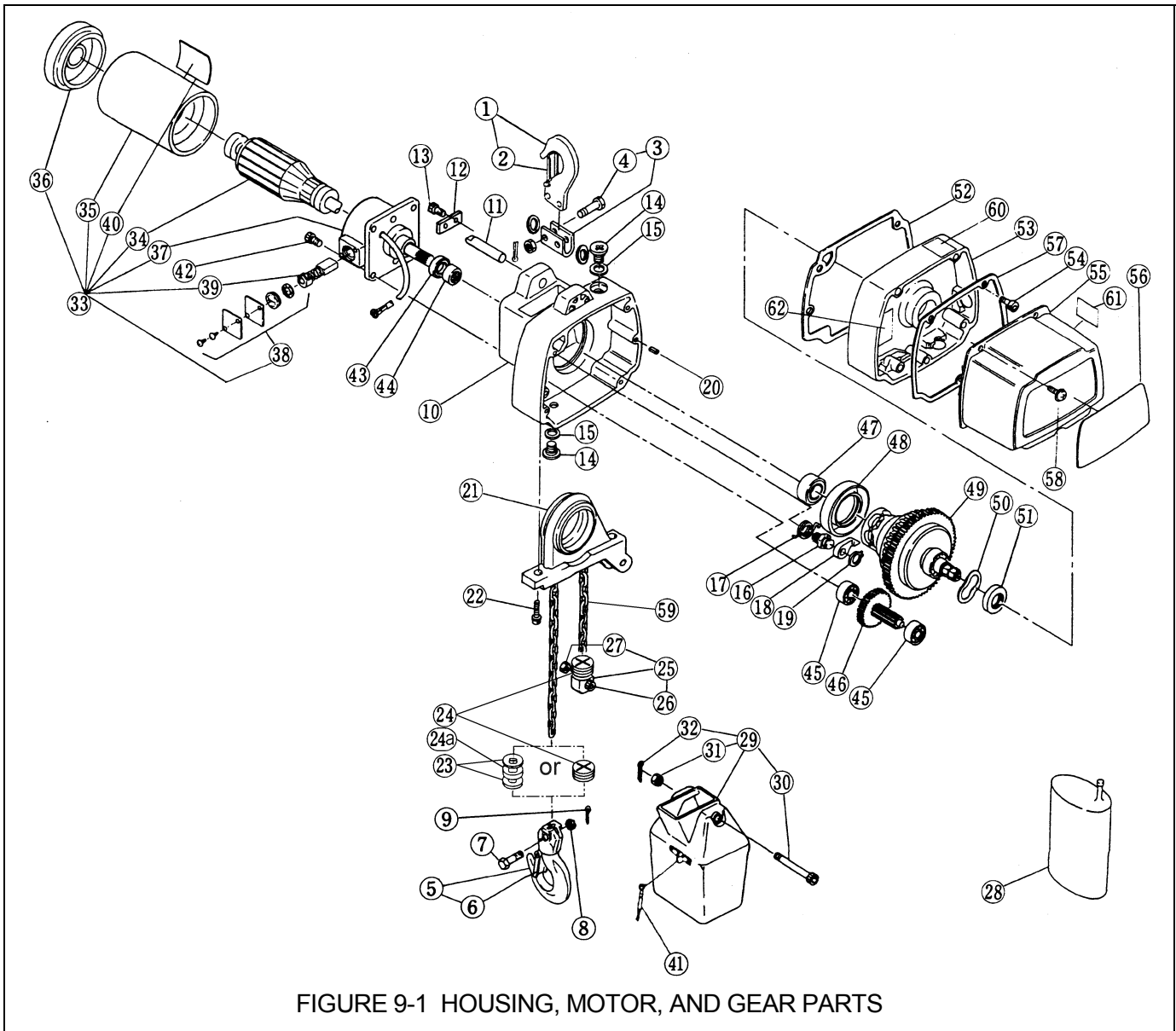

FIGURE 9-1 HOUSING, MOTOR, AND GEAR PARTS

9.1 Housing, Motor, and Gear Parts

Fig. No.	Part Name	Parts Per Hoist	Capacity (lbs.)					
			125	220	250	400	350	525
1	Top Hook Assembly	1	E2D1001125					
2	Hook Latch Assembly	1	L41071008					
3	Top Yoke Complete Set	1	E2D10111125				E2D1011350	
4	Top Pin Assembly	2	M3041010					
5	Bottom Hook Comp. Set	1	E2D1021125					
6	Latch Assembly. B	1	CF071005					
7	Chain Pin	1	E2D041125					
8	Slotted Nut	1	E2D049125					
9	Split Pin	1	9009402					
10	Body (ED2B Model)	1	E2D101125				E2D101350	
	Body (ED3A Model)	1	E3DBX10S9101				E3DBX24S9101	
11	Top Pin E	1	E2D117125				E2D117350	
12	Shaft Stopper	1					E2D118350	
13	Socket Bolt w/ Spring Washer	2					E2D072350	
14	Oil Plug	2	E3S111003					
15	Plug Packing	2	E3S112003					
16	Pawl Pin	1	E2D269125					
17	Pawl Spring	1	E2D270125					
18	Pawl	1	L4155015					
19	Snap Ring	1	L4188015					
20	Set Pin	2	CF083020					
21	Chain Guide (ED2B Model)	1	E2D401125				E2D401350	
	Chain Guide (ED3A Model)	1	E3DBX10S9401				E3DBX24S9401	
22	Socket Bolt w/ Spring Washer	2	E2D451125					
23	Washer (ED2B Model only)	2	E2D048125					
24	Cushion Rubber (ED3A Model)	2	* E3DBX10S9046					
24a	Cushion Rubber (ED2B Model)	2	E2D046125					
25	Stopper Complete Set	1	E2D1045125					
26	Socket Bolt w/ Spring Washer	1	E2D086125					
27	Lever Nut	1	E2D087125					
28	Gear Oil	1	E2D90B125				E2D90B350	
29	Chain Container 10 ft max lift for S&DS	1	E2D1831125					
	Chain Container 20 ft max lift for S&DS	1	E2D1835125					
	Chain Container 10 ft max lift for DA	1	E2D1831D125				E2D1831D350	
30	Socket Bolt BP	1	E2D854125					
31	U Nut	1	E2D853125					
32	Split Pin	1	9009402					
41	Clamp for DA	1	9006602					

*Use this P/N as a replacement for Figure No.'s 23 & 24a. Can be used For ED2B & ED3A Models.

9.1 Housing, Motor, and Gear Parts

Fig. No.	Part Name	Parts Per Hoist	Capacity (lbs.)					
			125	220	250	400	350	525
33	Motor Complete Set for 120V, 50/60 Hz	1	E2D1501P125				E2D1501P350	
34	Armature Assembly for 120V, 50/60 Hz	1	E2D5508P125				E2D5508P350	
35	Stator Assembly	1	E2D5507P125				E2D5507P350	
36	Motor Cover	1	E2D509P125				E2D509P350	
37	Motor Flange	1	E2D506P125				E2D506P350	
38	Lid Assembly	2	E2D1510P125				E2D1510P350	
39	Carbon Brush	2	E2D502P125				E2D502P350	
40	Name Plate M	1	E2D802P125		E2D802P250		E2D802P350	
42	Socket Bolt w/ Spring Washer	4	E2D162125					
43	Oil Seal	1	E2D221125					
44	Needle Roller Bearing	1	E2D222125					
45	Ball Bearing	2	9000100					
46	Gear #2 Assembly	1	E2D1223-125	E2D1223-220	E2D1223250		E2D1223-350	E2D1223-525
47	Ball Bearing	1	E2D238125				E2D238350	
48	Oil Seal	1	E2D236125				E2D236350	
49	Friction Clutch Assembly (Including Load Sheave)	1	E2D5234-125	E2D5234-220	E2D5234-250	E2D5234-400	E2D5234-350	E2D5234-525
50	Set Spring	1	E2D311125				E2D311350	
51	Oil Seal	1	E2D239125				E2D239350	
52	Gear Cast Packing	1	E2D125125				E2D125350	
53	Gear Case	1	E2D105125				E2D105350	
54	Socket Bolt w/ Spring Washer	4	E2D152125					
55	Controller Cover	1	E2D104125				E2D104350	
56	Name Plate B (ED2B Model)	1	E2D801-125	E2D801-220	E2D801-250	E2D801-350	E2D801-400	E2D801-525
	Name Plate B (ED3A Model) Single Speed	1	EDHX06-S9801	EDHX10-S9801	EDHX18-S9801	EDHX18-S9800	EDHX16-S9801	EDHX24-S9801
	Name Plate B (ED3A Model) Dual Speed	1	EDHX06-R9801	EDHX10-R9801	EDHX18-R9801	EDHX18-R9800	EDHX16-R9801	EDHX24-R9801
57	Controller Cover Packing	1	E2D109125				E2D109350	
58	Machine Screw w/ Spring Washer	3	MS554010					
59	Load Chain	Ft.	LCED125					
60	Warning Seal EO	1	E2D865125					
61	Warning Seal EE	1	E2D866125					
62	Warning Seal EF	1	E2D867125					

This Page Intentionally Left Blank

9.2 Power Supply and Pendant Parts

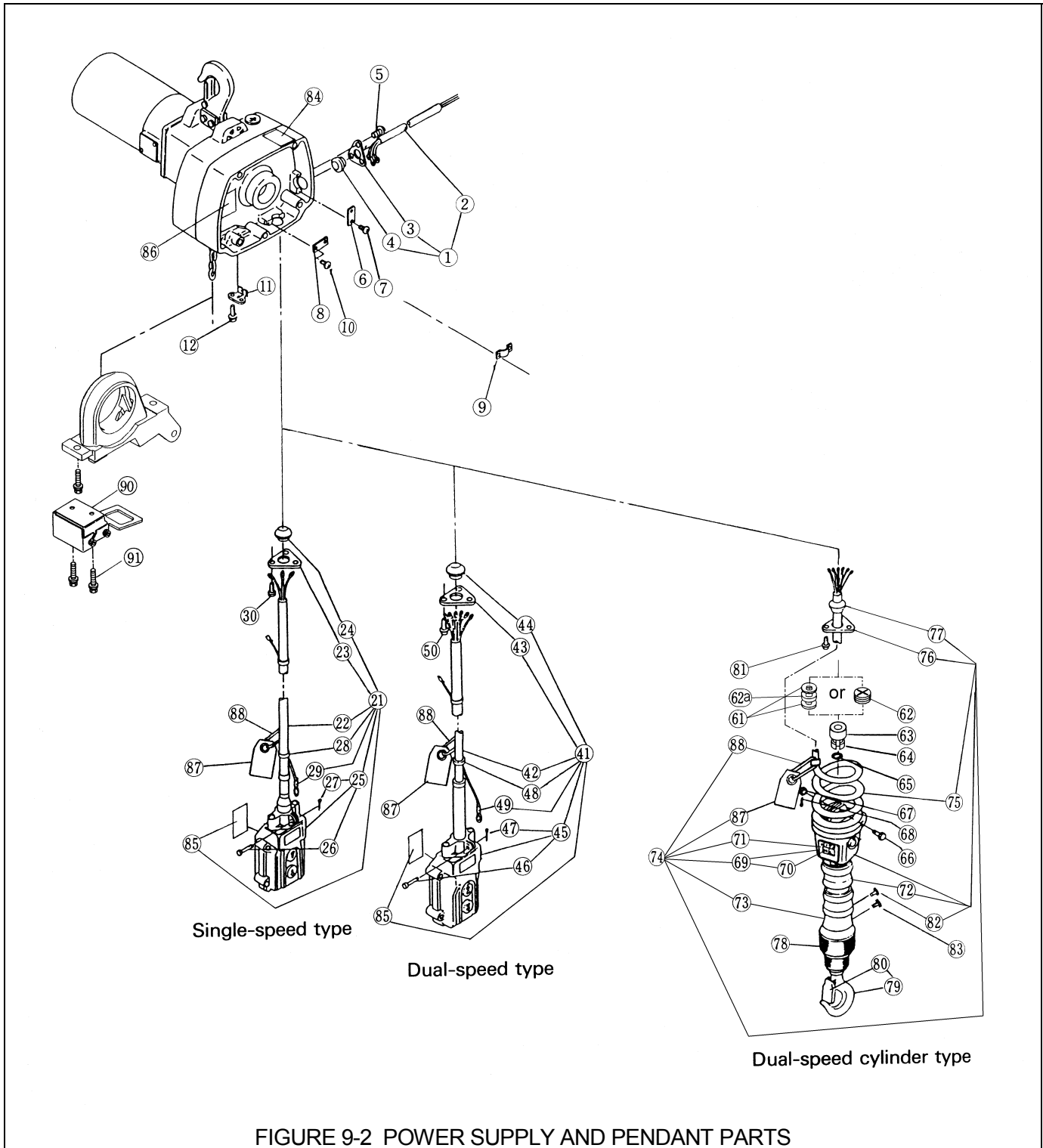

FIGURE 9-2 POWER SUPPLY AND PENDANT PARTS

9.2 Power Supply and Pendant Parts

Fig. No.	Part Name	Parts Per Hoist	Capacity (lbs.)					
			125	220	250	400	350	525
1	Power Supply Cable 3C Complete Set	1	E2D1521125					
2	Power Supply Cable 3C	1	E2D521125					
3	Cable Holder C	1	E2D537125					
4	Cable Packing C8	1	E2D524125					
5	Machine Screw w/ Spring Washer	3	MS554010					
6	Cable Clamp E8	1	E2D541125					
7	Machine Screw w/ Spring Washer	2	MS556010					
8	Cable Clamp E8 (Single Speed)	1	E2D541125					
9	Cable Clamp E12 (Dual/Cylinder)	1	E2D542125					
10	Machine Screw w/ Spring Washer	2	MS556010					
11	Cable Support L	1	E2D543125					
12	Machine Screw w/ Spring Washer	2	MS554010					
21	Push Button Cord 3C Complete Set	1	E2D1607P125				E2D1607P350	
22	Push Button Cord 3C	1	E2D607125					
23	Cable Holder C	1	E2D537125					
24	Cable Packing C8	1	E2D524125					
25	Push Button Switch S Assembly	1	E2D1615125					
26	Cord Chain Pin	1	ES628003					
27	Split Pin	1	9009402					
28	Lock-Belt	3	E2D640125					
29	Fixing Sleeve	1	9012301					
30	Machine Screw w/ Spring Washer	3	MS554010					
41	Push Button Cord 6C Complete Set	1	E2D1607PD125				E2D1607PD350	
42	Push Button Cord 6C	1	E2D607D125					
43	Cable Holder C	1	E2D537125					
44	Cable Packing C12	1	E2D525125					
45	Push Button Switch D Assembly	1	E2D1615D125					
46	Cord Chain Pin	1	ES628003					
47	Split Pin	1	9009402					
48	Lock-Belt	3	E2D640125					
49	Fixing Sleeve	1	9012301					
50	Machine Screw w/ Spring Washer	3	MS554010					
61	Washer (Model ED2B)	2	E2D048125					
62	Cushion Rubber (Model ED3A)	2	* E3DBX10S9046					
62a	Cushion Rubber (Model ED2B)	2	E2D046125					
63	Stopper Collar	1	E2D044125					
64	Stopper	2	E2D045125					
65	Snap Ring	1	9047220					
66	Chain Pin	1	E2D041125					

*Use this item as a replacement for item 61 & 62a. Can be used for ED2B & ED3A Models.

9.2 Power Supply and Pendant Parts

Fig. No.	Part Name	Parts Per Hoist	Capacity (lbs.)					
			125	220	250	400	350	525
67	Slotted Nut	1	E2D049125					
68	Split Pin	1	9009402					
74	Push button Cord 6C Complete Set	1	E2D1607PD125C				E2D1607PD350C	
69	*High/Low Switch Assembly	1	* E2D60A125					
70	*High/Low Light	1	* E2D615125					
71	*Back Plate	1	*E2D60B125					
72	*Movable Grip	1	*E2D648125					
73	*Fixed Grip	1	*E2D649125					
75	Push Button Coil Cord 6C	1	E2D607H125					
76	Cable Holder C	1	E2D537125					
77	Cable Packing C12	1	E2D525125					
82	*Flat Head Screw for Fixed Grip	1	*9096528					
	**Truss Head Screw for Fixed Grip		**TRUSSM4X10					
87	Warning Tag LD	1	E2D931125					
88	Chain Stopper Link	1	E2D045D125					
78	Detachable Fitting E	1	E2D5041125					
79	Detachable Hook Assy.	1	E2D1002125					
80	Latch Assy.	1	CF071005					
81	Machine Screw w/ Spring Washer	1	E2D555125					
83	Flat Head Screw (attaches figure 79 to 74)	1	9096529					
84	Warning Seal EO	1	E2D865125					
85	Warning Seal EE	1	E2D866125					
86	Warning Seal EF	1	E2D867125					
90	Limit switch Assembly (ED3A Model only)	1	E3DBX10S1411				E3DBX24S1411	
91	Socket Bolt w/ Spring Washer (ED3A Model only)	2	J1BG2-0401010					

* Available as an individual part only for models equipped with illuminated High/ Low push button switch.

** For models with rubber bellow above the movable grip.

This Page Intentionally Left Blank

9.3 Electric Parts

Fig. numbers 5, 6, 8, and 10
notshown

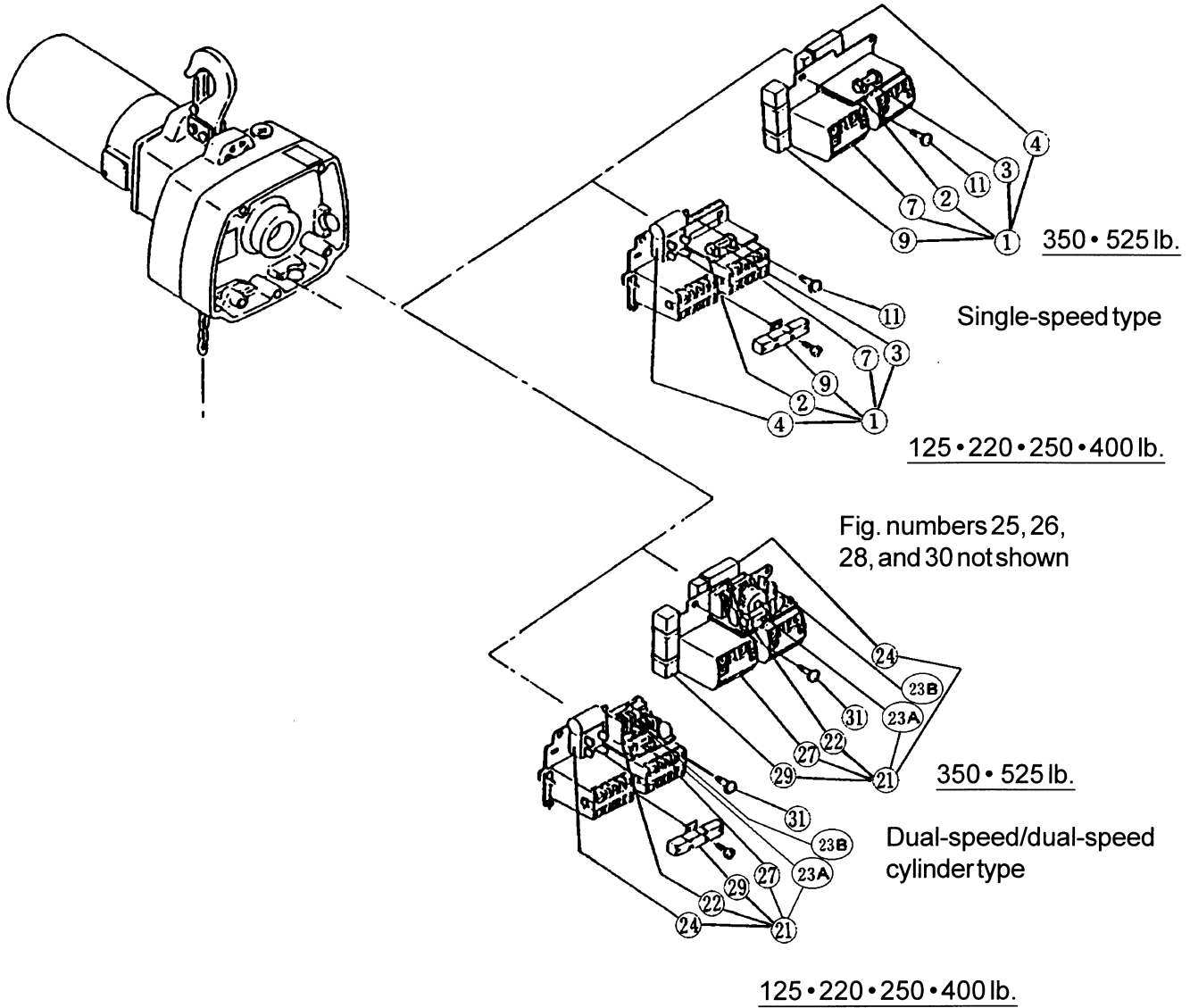

FIGURE 9-3 ELECTRIC PARTS

9.3 Electric Parts

Fig. No.	Part Name	Parts Per Hoist	Capacity (lbs.)					
			125	220	250	400	350	525
1	Control Panel Complete Set	1	E2D1601P125				E2D1601P350	
2	Converter Assembly	1	E2D616125				E2D616350	
3	Fuse	1	E2D664125				E2D664350	
4	Silicone Stack Assembly	1	E2D622125				E2D622350	
5	Machine Screw w/ Spring Washer (for converter)	2	E2D667125					
6	Machine Screw w/ Spring Washer (for silicone stack)	1	MS557010					
7	Electromagnetic Contactor	2	E2D617P125					
	Electromagnetic Contactor Complete Set	1					E2D617P350	
8	Machine Screw w/ Spring Washer (for Contactor)	4	MS555010					
	Machine Screw w/ Spring Washer (for base)	4					E2D667125	
9	Resistor	1	E2D619P125				E2D619P350	
10	Machine Screw w/ Spring Washer (for resistor)	9					MS557010	
11	Socket Bolt w/ Spring Washer	3	E2D651125					
		4					E2D651350	
21	Control Panel Complete Set	1	E2D1601PD125				E2D1601PD350	
22	Converter Assembly	1	E2D616PD125				E2D616PD350	
23A	Fuse F2	1	E2D664125				E2D664350	
23B	Fuse F3 (0.1 AMP)	1	9006237					
24	Silicone Stack Assy.	1	E2D622125				E2D622350	
25	Machine Screw w/ Spring Washer (for converter)	2	E2D667125					
26	Machine Screw w/ Spring Washer (for silicone stack)	1	MS557010					
27	Electromagnetic Contactor	2	E2D617P125					
	Electromagnetic Contactor Complete Set	1					E2D617P350	
28	Machine Screw w/ Spring Washer (for Contactor)	5	MS555010					
	Machine Screw w/ Spring Washer (for base)	2					E2D667125	
29	Resistor	1	E2D619P125				E2D619P350	
30	Machine Screw w/ Spring Washer (for resistor)	9					MS557010	
31	Socket bolt w/ Spring Washer	3	E2D651125					
		4					E2D651350	

9.4 Mini Trolley Parts

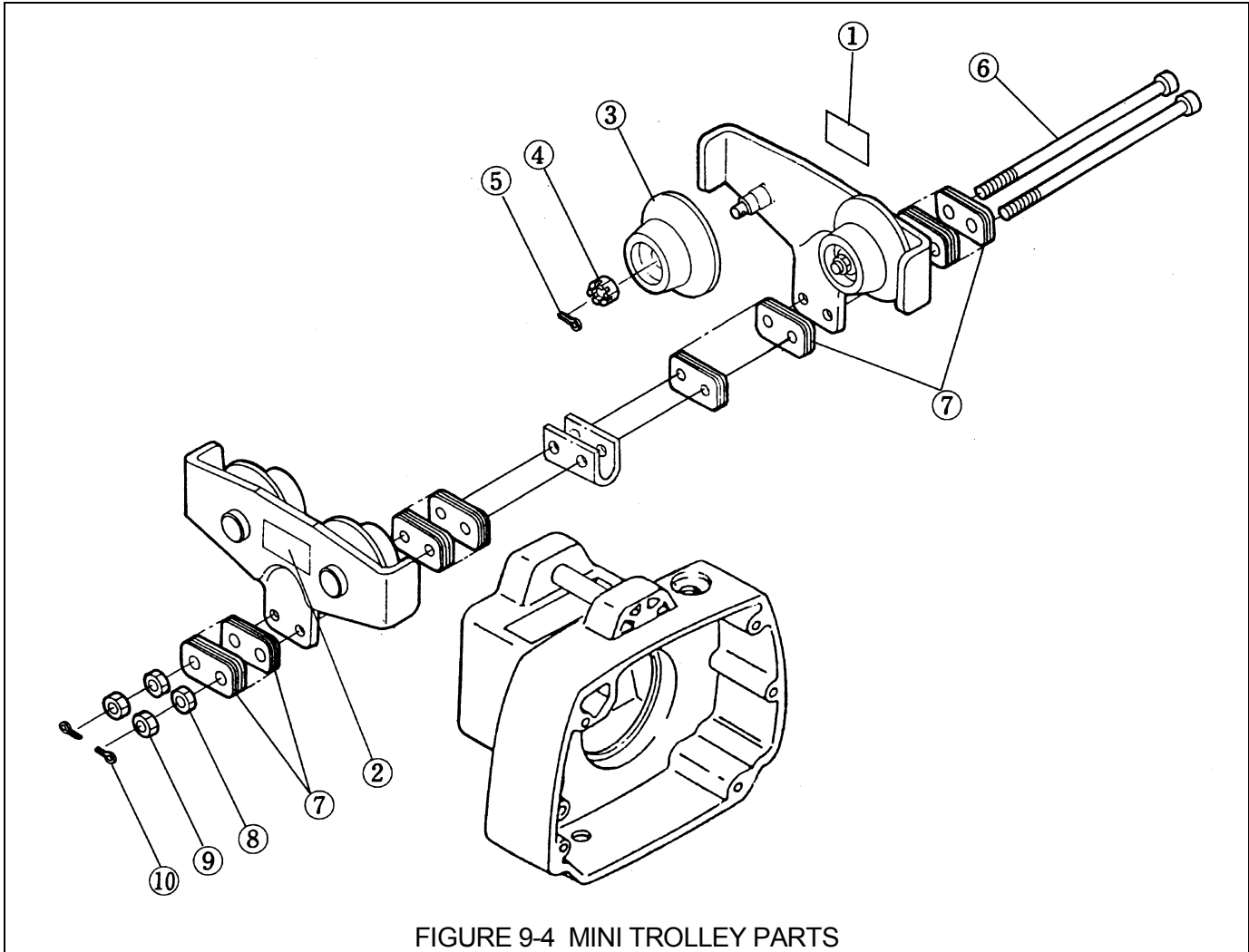

FIGURE 9-4 MINI TROLLEY PARTS

9.4 Mini Trolley Parts

Fig. No.	Part Name	Parts Per Hoist	Capacity (525lbs.)
1	Name Plate C	1	ET25801525
2	Name Plate B	1	ET25800525
3	Track Wheel Assembly	4	ET255102525
4	Slotted Nut	4	M2049010
5	Split Pin	4	9009411
6	Socket bolt	2	ET25115525
7	Adjusting Spacer	32	ET25116525
8	Nut	2	9093424
9	U Nut	2	ET25155525
10	Split Pin	2	9009411

Notes



www.harringtonhoists.com

Harrington Hoists, Inc.
401 West End Avenue
Manheim, PA 17545-1703
Phone: 717-665-2000
Toll Free: 800-233-3010
Fax: 717-665-2861

Harrington Hoists – Western Division
2341 Pomona Rincon Rd. #103
Corona, CA 92880-6973
Phone: 951-279-7100
Toll Free: 800-317-7111
Fax: 951-279-7500

EDOM